

FL-3M Faces

This machine should be used for applying the plastic material protection (film).

Apply and cut the film in **3 flat faces** of the profiles. Ideal curtain wall profile.

Vertical adjustable rollers in width , for a good centering and easy movement of the profiles filming.

The machine uses rollers as a film applicator, and the that is rotated by a motor and automatically cuts the film electrical resistance. This adequately protected.

The positioning and cutting of the film is done automatically, a sensor detects the onset of the profile, allowing the machine is then complete the process of placement.

The machine body is resistant ensuring their accuracy.

The high quality of this machine and its ease of operation make it suitable for use by operators.

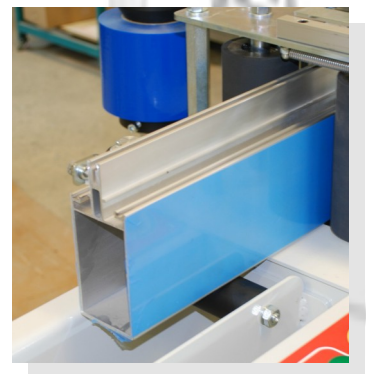
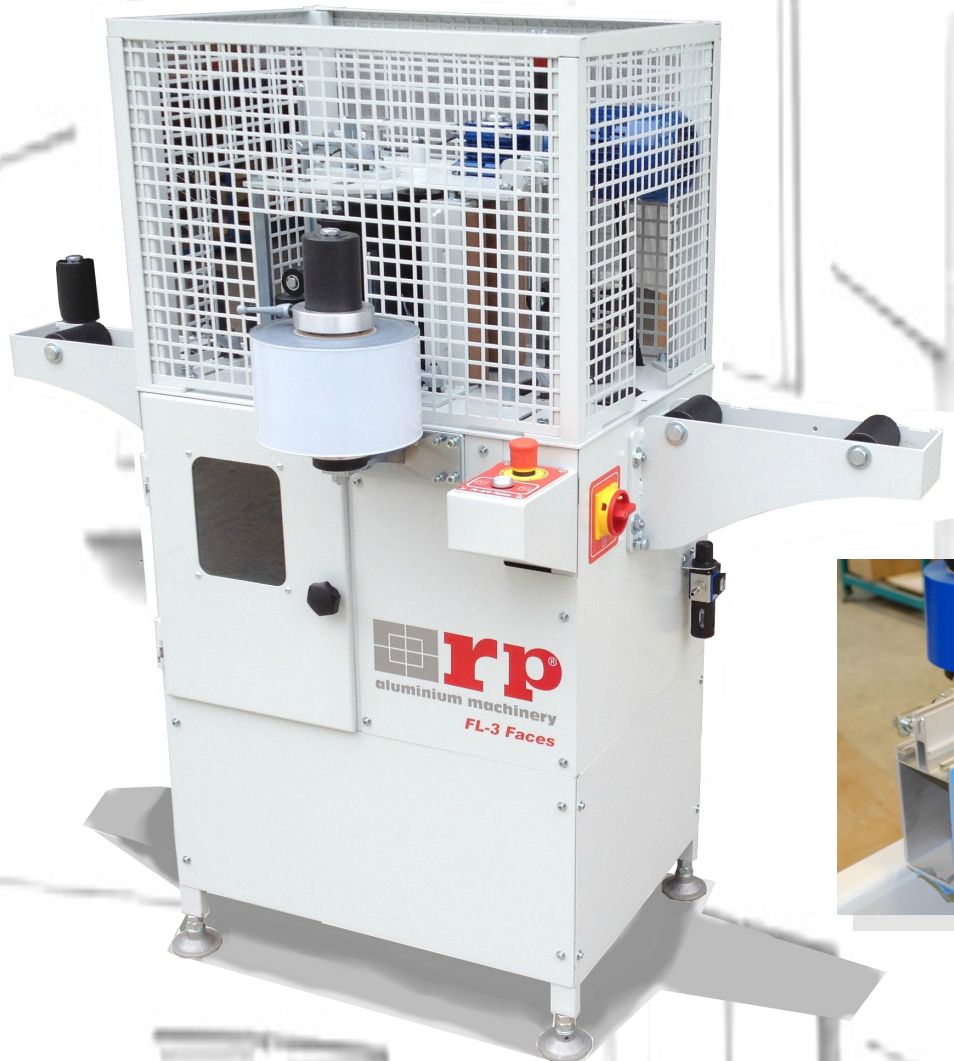

ESB-64058050 C/ Puigbarral, 44 Nau 4F Pol.
Ind. Can Petit 08227 TERRASSA, BARCELONA
(SPAIN)

Tel: (+34) 93 789 29 93
Mail: export@rpaluminium.com
admin@rpaluminium.com

 **rp**[®]
aluminium machinery

FL Family

FL-3M Faces

Technical Data

| | |
|------------------------|------------------|
| Maximum length profile | Unlimited |
| Height max. profile | 250 mm. |
| Width max. profile | 100 mm. |
| Height max. | 250 mm. |
| Width film coil | 100 mm. |
| Thick film coil | 35 a 100 microns |
| OutsideØ film coil | 300 mm. |
| Motor | 0 / 5 CV |
| Working pressure | 1-6 kg. |
| Working height | 940 mm |

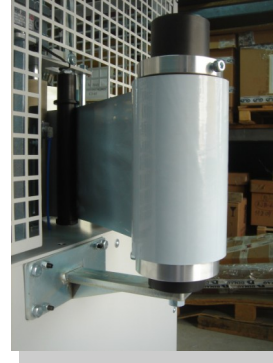

Overall Dimensions

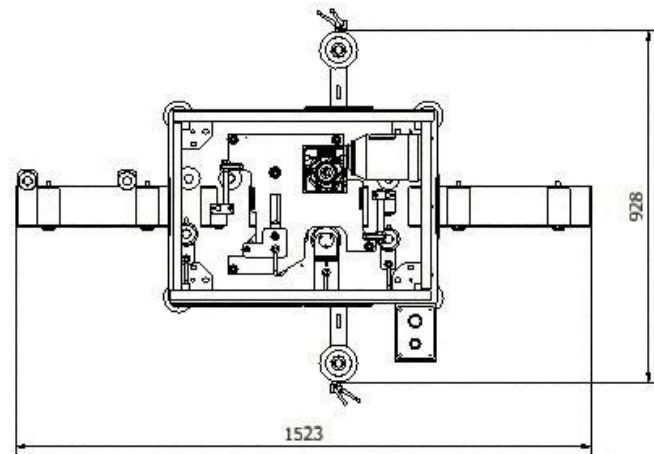
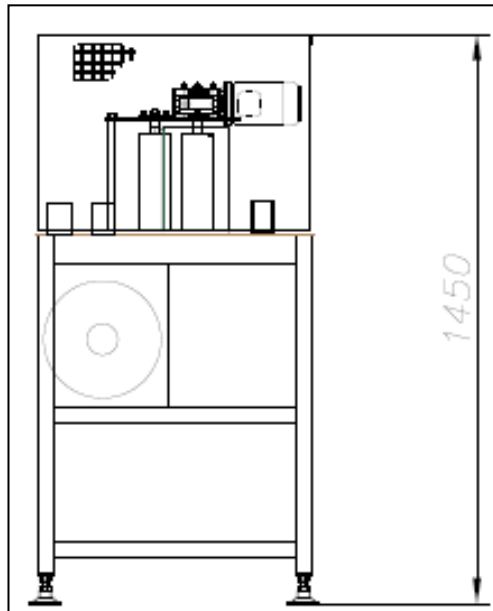

ADDITIONAL MATERIAL

Roller bench entry 0,5 m.
Roller bench exit 0,5 m.
Installation, use and maintenance.

OPTIONAL MATERIAL

Roller bench entry and exit 3,9 m. Ref.: BR-1
Roller bench entry and exit 1,85 m. Ref.: BR-2
Downloader profiles. Ref.: DES-2

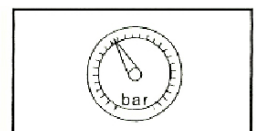
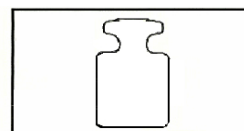

Mono 220v 1Kw –
230V –50/60 HZ

160 kg.

6 + 7 bar